

SA SELECTORIZED SERIES

SA038 - 5 STACK MULTI-STATION

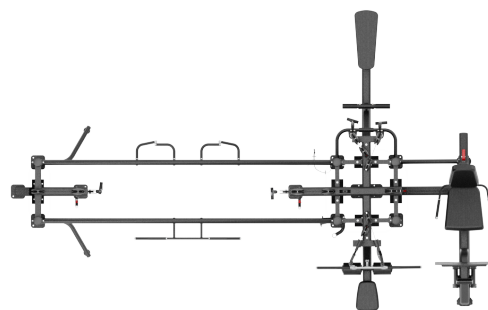
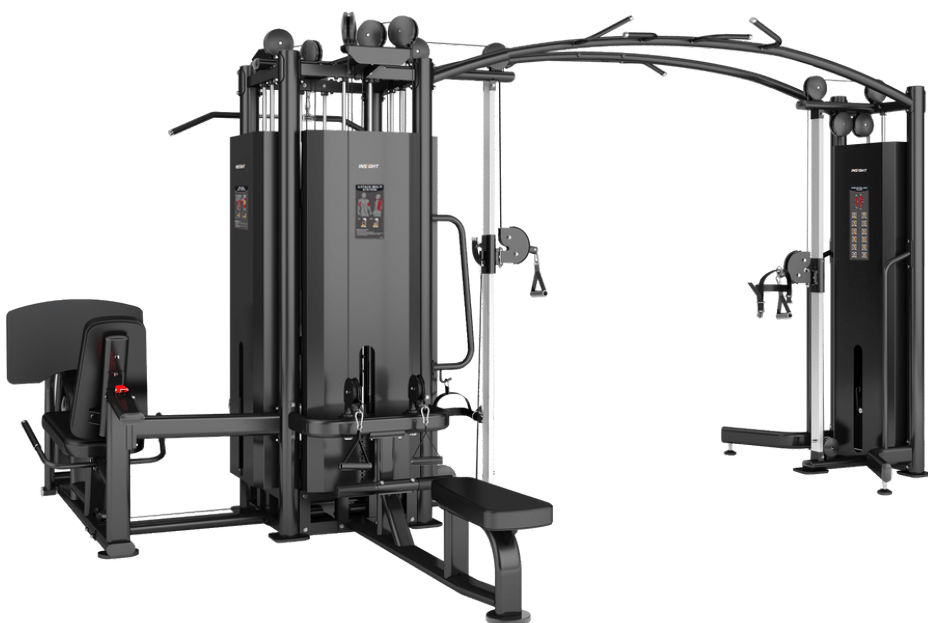

PRODUCT OVERVIEW

The SA038 is a five-stack selectorized strength training machine built on the SA Multi-Station Training System. Designed for modern commercial fitness facilities, it integrates five core training modules to support multiple users simultaneously, significantly enhancing both space utilization and training efficiency. With its compact footprint and multi-user capacity, the SA038 serves as a highly functional and indispensable centerpiece in any gym layout.

Crafted with a robust frame and precision manufacturing, the machine maintains exceptional stability and safety under high-intensity use. Each station is ergonomically engineered and equipped with precise adjustment options, compatible with a wide range of attachments and movement paths. The SA038 supports systematic, full-body strength training across major muscle groups—including back, core, and lower body—while adapting to different body types and training goals. It is an ideal solution for open training areas, personal training sessions, and functional zones a.

SPECIFICATIONS & KEY FEATURES

Specifications

Dimension:	5025*3350*2388mm
Total Weight:	1024kg
Weight Stack:	100kg*5
Max Weight Stack:	125kg*5

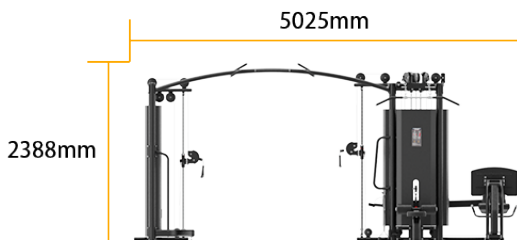
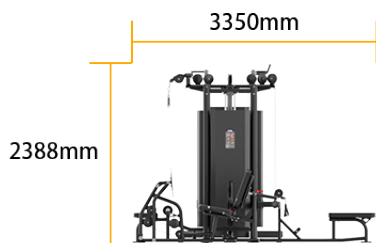
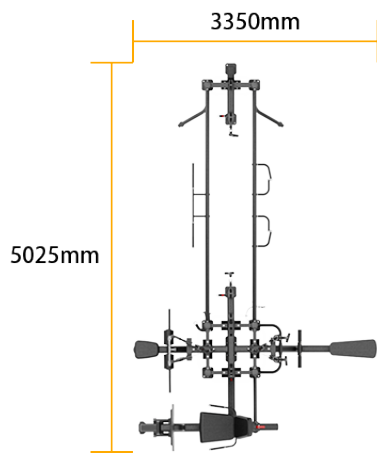

Product Features



Low Row Module

Targeted at building back thickness, this module features a high-precision pulley system for enhanced motion stability and accuracy. The independent handle design allows for symmetrical back development, preventing imbalances due to uneven strength. Compared to traditional footplates, the horizontal bar offers greater ankle mobility. The extra-long seat rail supports a full range of motion, ensuring consistent muscle engagement throughout the exercise.



Lat Pulldown Module

Engineered for increasing back width, the high-mounted pulley ensures full-range activation of back muscle fibers. The split pulley system supports both wide-grip and unilateral pulldown movements for more versatile training. A 10-position adjustable thigh pad ensures user stability, while the optimized seat height promotes natural posture and smooth power output, improving overall training comfort and effectiveness.



Seated Leg Press Module

Designed to train the quadriceps, glutes, hamstrings, and adductors, this station combines a high-precision linear guide with a smooth pulley system for optimal motion fluidity. The ultra-wide anti-slip footplate supports various foot positions, from narrow to wide stance, high to low placement. The 10-position adjustable backrest accommodates users of different heights and leg lengths, ensuring proper hip-knee alignment and maximizing safety and training effectiveness.



Adjustable Dual Pulley Module

Equipped with a dual-grip, dual-bridge pull-up bar, this module offers a wide range of grip angles from wide to narrow, catering to different back and core training objectives. The double-bridge design enhances stability and prevents interference between users. The pulley system allows for 32 height settings, enabling seamless transition between high, mid, and low pulley movements. Dual side handles provide added support during lower body or balance-based training, enhancing body control and movement quality.